

TCDHFL, TCDHF TOGGLE CLAMPS

RHS Stainless Steel

IMAO



TCDHFL-SUS

(With Safety-Lock Feature, Stainless Steel)

Type	Body/Arm	Handle	Knob Cover
TCDHFL	Steel(SAPH440) (Steel(SPEC340) for M4 size)	Polyamide	Thermoplastic elastomer
TCDHF	Nitrocarburized Black oxide finish		-
TCDHFL-SUS	SUS304		Thermoplastic elastomer
TCDHF-SUS	stainless steel		-

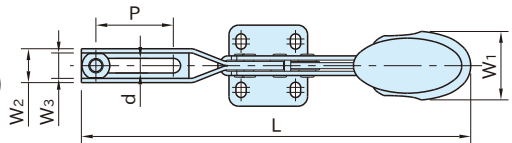

TCDHFL TCDHFL-SUS

(With Safety-Lock Feature)



TCDHF

(Without Safety-Lock Feature, Steel)

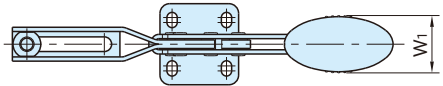

TCDHF TCDHF-SUS

(Without Safety-Lock Feature)

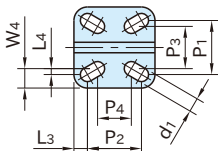
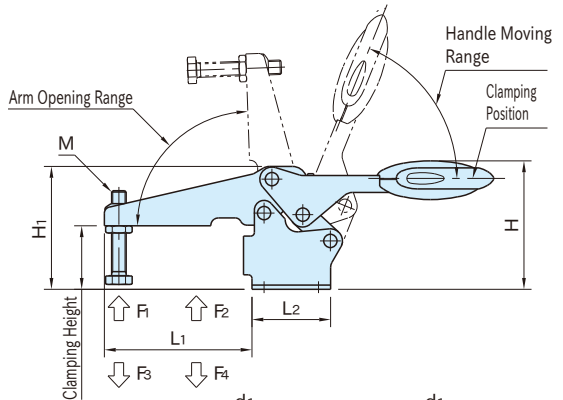
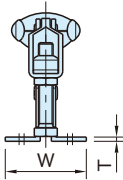

M4 Size

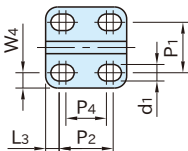

M5 Size

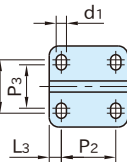

M6~10 Size

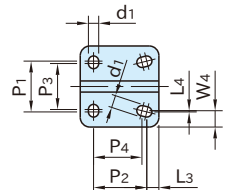

M12 Size

Type/Size	Arm Opening Range	Handle Moving Range	Handle Force (N)	Holding Force *)		Clamping Force		M	Clamping Height	
				F ₁ (kN)	F ₂ (kN)	F ₃ (kN)	F ₄ (kN)			
TCDFHL	04	87°	69°	80	0.4	0.5	0.25	0.3	M 4×0.7 -16L	11.7
	05	86°	67°	100	0.65	0.9	0.5	0.62	M 5×0.8 -25L	17.2
TCDFH	06			160	1.35	1.9	0.65	1.2	M 6×1 -35L	25.4
TCDFHL-SUS	08			200	2.0	2.8	0.75	1.4	M 8×1.25-45L	32.2
TCDFH-SUS	10			90°	71°	250	2.2	4.5	0.84	M10×1.5 -55L
	12	88°	68°	280	2.4	5.5	0.8	1.6	M12×1.75-70L	52.3

Type/Size	d	P	L ₁	L ₂	W	T	d ₁	P ₁	P ₂	P ₃ **)	P ₄ **)	L ₄	L ₃	W ₄	H ₁	W ₂	W ₃	
TCDFHL	04	4.1	13	23.7	24	24	1.5	4.2	16	16	12.5	10	1.75	4	5.8	26.3	10.2	7.1
	05	5.1	20	41.8	27	27	2	5.5	16.8	18	-	13.5	-	4.5	5.1	38.9	13.2	9.1
TCDFH	06	6.1	32	60.5	39	39	2.5		28	26	24.6	-	-	6.5	-	59.5	17.5	12.4
TCDFHL-SUS	08	8.2	37	74.9	44	45		6.2	31	26	26.1	-	-	9	-	70	21	15.7
TCDFH-SUS	10	10.2	54	103.9	59	59	3.5	8.8	43	41.5	39	-	-		-	87.9	26	18.7
	12	12.1	64	122	65	67		8.5	42	44	40	40	1	10	13.5	101.6	28	20.9

*) Never apply a force over this value when machining from below.

) For **TCDFH 0408, "P₃" and "P₄" are actually 14.1 and 12.74 respectively.

TCDFHL **TCDFHL-SUS** (With Safety-Lock Feature)

Steel		Stainless Steel		L	W ₁	H
Part Number	Weight(g)	Part Number	Weight(g)			
TCDFHL06160	343	TCDFHL06160-SUS	343	193.3	53.4	63.7
TCDFHL08200	436	TCDFHL08200-SUS	436	230.3	51.1	73.9
TCDFHL10250	841	-	-	286	56.5	94.8
TCDFHL12280	1053	-	-	321.3		104.8

TCDFH **TCDFH-SUS** (Without Safety-Lock Feature)

Steel		Stainless Steel		L	W ₁	H
Part Number	Weight(g)	Part Number	Weight(g)			
TCDFH04080	45	TCDFH04080-SUS	47	91.8	20	29.3
TCDFH05100	96	TCDFH05100-SUS	96	125.7	22.5	43.4
TCDFH06160	318	TCDFH06160-SUS	318	186.6	43.5	63.7
TCDFH08200	408	TCDFH08200-SUS	408	223.1	41.5	73.9
TCDFH10250	812	-	-	279.3	47	94.8
TCDFH12280	1028	-	-	314.7		104.8

Features:

- User-friendly handle
- The safety-lock version allows the clamp to be locked at the clamping position and stay locked until manually unlocked by sliding the knob cover before opening. This prevents the clamp from being accidentally opened by bumping the handle.

Related Product Page

Spindle nuts **TCDNUT** are available separately

Note:

The clamping spindle may have a marking on the top of the hex head. Remove it as needed.

How To Use (TCDFHL & TCDFHL-SUS type)

