

# SW

## SWING C WASHERS

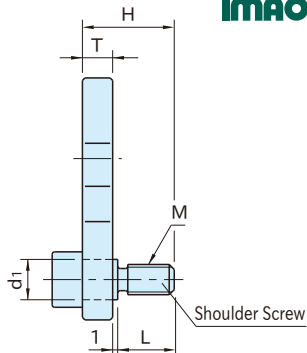
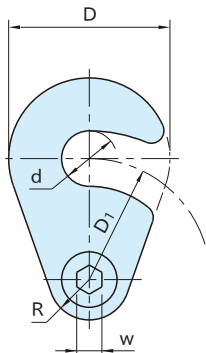

Type	Washer	Shoulder Screw
<b>SW6</b>	Steel(S50C) Black oxide finish	Steel(S45C) Black oxide finish
<b>SW8</b>	Heat treated to Rc39-45	
<b>SW10</b>	Steel(S45C)	Steel(S45C) Heat treated to Rc33-39
<b>SW12</b>	Black oxide finish	
<b>SW16</b>	Heat treated to Rc39-45	

Part Number	D	D <sub>1</sub>	d	T	M	L	w	H	R	d <sub>1</sub>	Weight (g)	Shoulder Screws
<b>SW 6</b>	20	18	6.6	6	M6×1	8	5	15	R 8	8	26	SW10-02
<b>SW 8</b>	26	21	9								34	
<b>SW10</b>	32	24	11								47	
<b>SW12</b>	40	27	13.5	8	M8×1.25	11	6	20	R10	10	90	SW12-02
<b>SW16</b>	50	33	18								125	