

QLSW

SWING CLAMPS (Standard)



With Handle

Without Handle

Body / Shaft	Clamp Arm / Adaptor Head	Handle	Ball Knob
SCM440 steel Quenched and tempered Black oxide finish	S45C steel Quenched and tempered Black oxide finish	S45C steel Black oxide finish	ABS resin Black

Counterclockwise Clamping

Clockwise Clamping

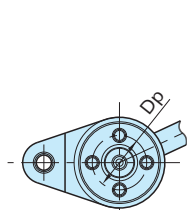
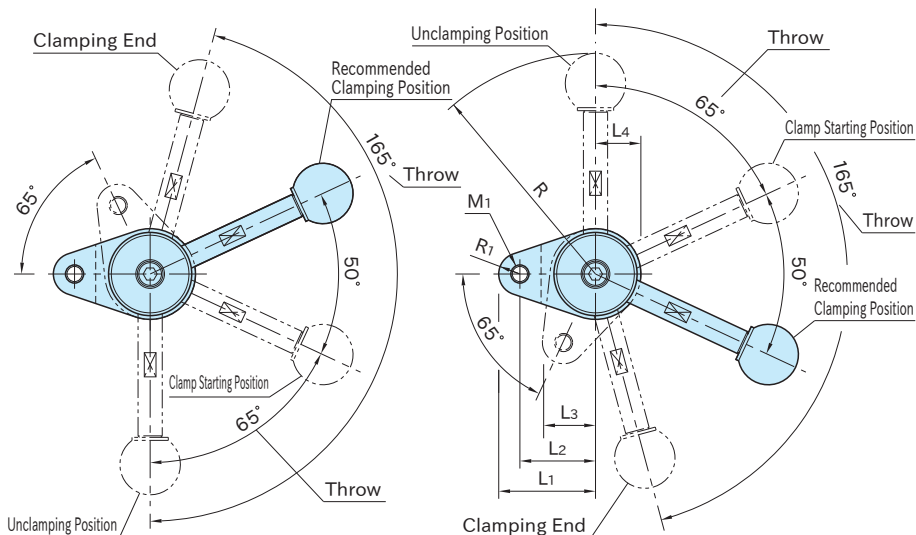

Bottom

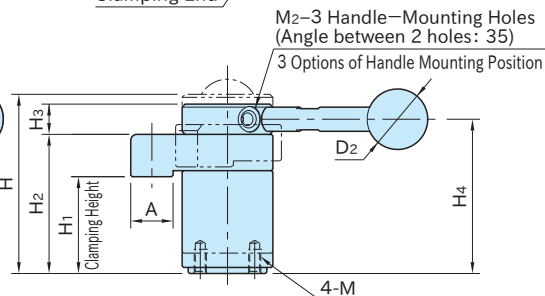
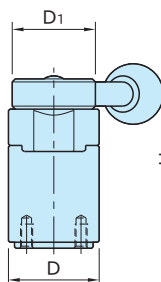

Size/Type	Clamping Direction	H ₁	A	R ₁	M ₁	L ₂	L ₁	L ₃	D	M	D _p
QLSW150R	CW	32	14	7	M6×1	25	32	17.5	30	M4×0.7 Depth 8	18
QLSW150L	CCW	*)									
QLSW200R	CW	45	16	8	M8×1.25	32	40	21.5	40	M6×1 Depth 12	25
QLSW200L	CCW	**)									

*) Actual clamping height: 31.4 to 32.6 (clamping stroke: 1.2)

**) Actual clamping height: 44.1 to 45.9 (clamping stroke: 1.8)

Size/Type	H	D ₁	H ₃	H ₂	M ₂	H ₄	L ₄	Clamping Force (kN)	Clamping Mechanism
QLSW150R	57.5	30	10	46	M5×0.8	51	15	0.8	Spiral Cam Cam Angle: 4°
QLSW150L									
QLSW200R	78.1	38	13	63	M6×1	69.5	20	1.2	
QLSW200L									

■ With Handle

Part Number	R	D ₂	Allowable Operating Load (N) ***)	Weight (g)
QLSW150R	73	20	150	320
QLSW150L				
QLSW200R	107	25	200	710
QLSW200L				

***) Allowable load to operate the handle

■ Without Handle

Part Number	Weight (g)
QLSW150NR	295
QLSW150NL	
QLSW200NR	660
QLSW200NL	

Note : The handle must be ordered separately.

- [QLSL](#) STANDARD HANDLES
- [QLTL](#) ADJUSTABLE-TORQUE HANDLES

■ Tip Installation

When installing a tip on the clamp arm, lock the clamp arm using a wrench to prevent the clamp from receiving any torque.

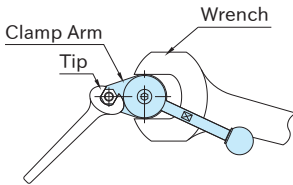

How To Use

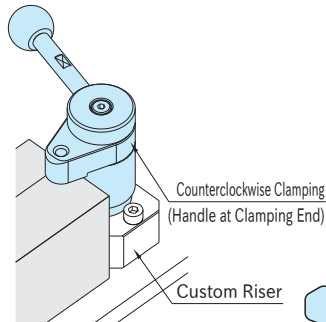
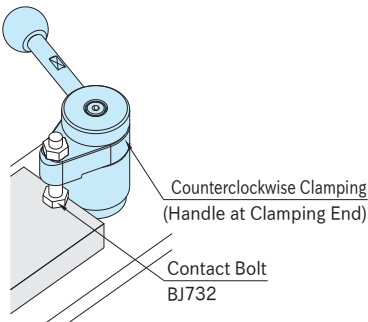

Continuing to next page

Technical Information

Allowable Loads in Machining of Workpiece Bottom

Type	Allowable Force To Workpiece Bottom (Per Clamp)
QLSW150	max. 2.1kN
QLSW200	max. 2.7kN

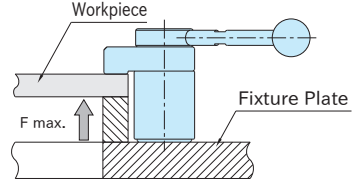

Performance Curve

QLSL STANDARD HANDLES

⚠ The performance curves shown below do not denote the guaranteed performance.

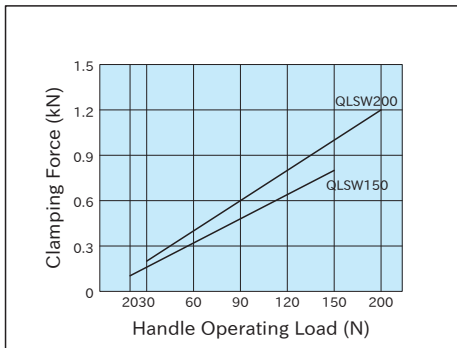

QLTL ADJUSTABLE-TORQUE HANDLES

Use a force gauge when measuring handle-operating loads.

⚠ The performance curves shown below do not denote the guaranteed performance.

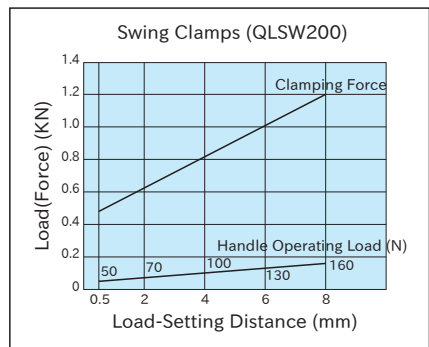
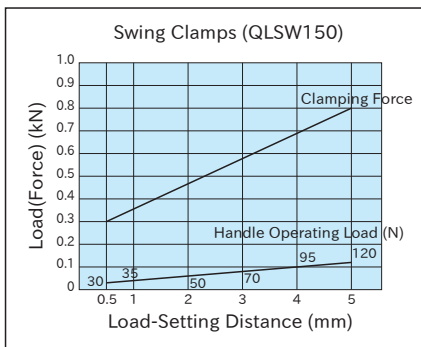
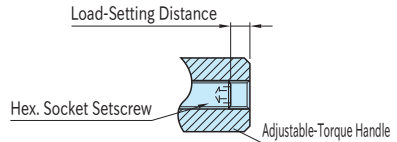

Clamp Arm

■ Custom Clamp Arm

Recommended Dimensions

Type	L ₅ (Max. *)	L ₆	W	H ₆	L ₇	d (F8)	R ₂	B	H ₇	M ₃	C
QLSW150	45	15	30	12	32	10	11	1.5	5	M4×0.7	C5
QLSW200	55	20	40	16	42	16	15	2	6	M5×0.8	C8

*) See page [QLSW-SH](#) clamping force vs. clamp - arm length

■ Installation / Removal

To install a clamp arm,

1. Fit it onto the shaft getting the stop pin received in the stop-pin slot provided on the clamp-arm bottom.
2. Place the adaptor head onto the shaft getting the shaft fitted into the shaft-receiving pocket in the adaptor head, and then lock the adaptor head using a hex. socket head cap screw.
3. Tighten the ball plungers inside the clamp arm.

To remove the clamp arm, follow the above steps back.

How to Determine H₅ Dimensions

Type	H ₂	H ₅
QLSW150	46	46—Clamping Height
QLSW200	63	63—Clamping Height

Ball Plunger

Type	Part Number
QLSW150	LBSTH4
QLSW200	LBSTH5

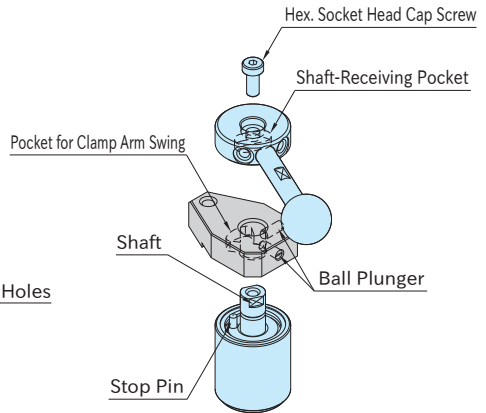
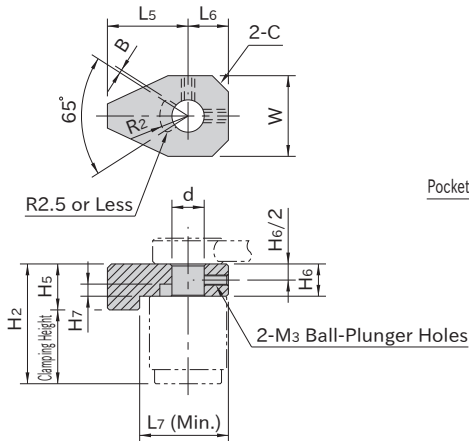

■ Clamp Arm Customization Examples

