



(CCW Clamping)
(With Handle)

(CW Clamping)
(Without Handle)

(CW Clamping)
(With Handle)

Note: Clamping Pins or Screws must be ordered separately.

★Key Point
Easy clamping without screws.

Body	Handle Shank	Ball Knob
SCM440 steel Quenched and tempered Black oxide finish	S45C steel Black oxide finish	ABS resin Black

Counterclockwise Clamping

Clockwise Clamping

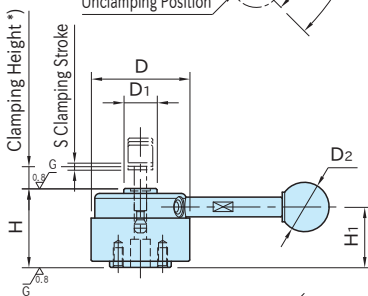
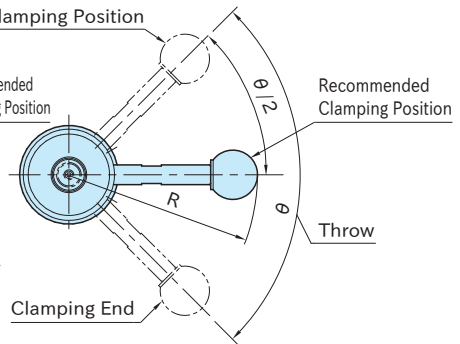
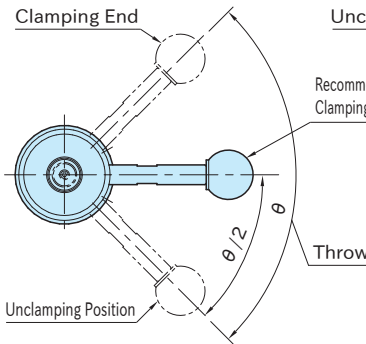

M1-3 Handle Mounting Holes
(Angle between 2 holes:30°)
3 Options of Handle Mounting Position

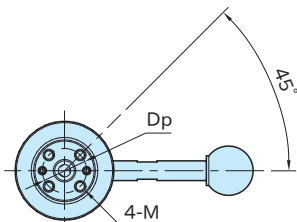
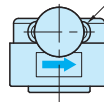

⊙ $\phi 0.02$ A d (Clamping-Pin or Clamping-Screw Setting Hole)

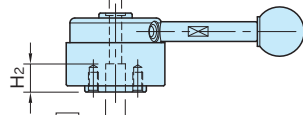

Locating-Pin Hole

Type	S	d (G6)	d ₁ (F7)	H ₂	D ₁	H (±0.01)	D	θ	Dp	M
QLPD150	1.5	8	5	10	13.5	32	40	90°	18	M4×0.7 Depth 8
QLPD200	2	12	8	13	18	40	50	110°	25	M6×1 Depth 9

Type	M ₁	H ₁	Clamping Force (kN)	Clamping Mechanism	Recommended Workpiece Thickness Tolerance **)
QLPD150	M5×0.8	24.5	0.9	Spiral Cam Cam Angle: 4°	±0.3
QLPD200	M6×1	30.7	2.5		±0.5

■ With Handle

Part Number	Clamping Direction	R	D ₂	Allowable Operating Load(N) ***)	Weight (g)
QLPD150R	CW	76.5	20	150	245
QLPD150L	CCW				
QLPD200R	CW	111.5	25	200	470
QLPD200L	CCW				

■ Without Handle ****)

Part Number	Clamping Direction	Weight (g)
QLPD150NR	CW	220
QLPD150NL	CCW	
QLPD200NR	CW	420
QLPD200NL	CCW	

*) Grip length of **QLPD-X** Clamping Pin (workpiece thickness)

**) Maintaining these recommended tolerances allows minimizing the variation of handle position in the clamping mode in clamping with the use of the Clamping Pin.

***) Allowable load to operate the handle.

****) The handle must be ordered separately.

- **QLSL** STANDARD HANDLES
- **QLTL** ADJUSTABLE-TORQUE HANDLES

How To Use

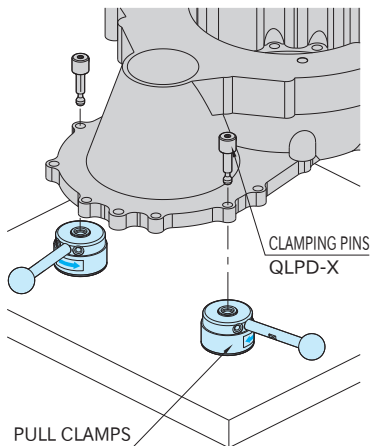

■ How to Locate Workpiece

1. Basic Method

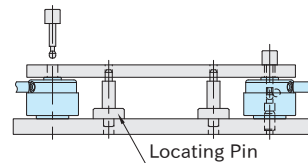

2. Method for clamping and locating a workpiece at a time

Give an accuracy shown below to the hole spacing to generate a locating accuracy of ±0.08.

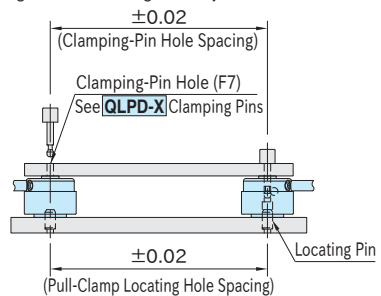

Technical Information

Allowable Loads in Machining of Workpiece Bottom

Ensure that a force more than indicated below is not applied to the workpiece bottom.

Type	Allowable Force To Workpiece Bottom (Per Clamp)
QLPD150	max.2 kN
QLPD200	max.5.5kN

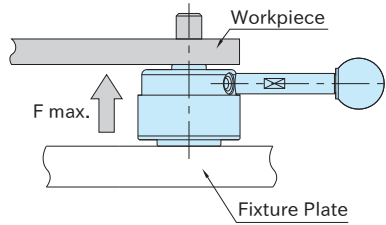

Performance Curve

QLSL STANDARD HANDLES

 The performance curves shown below do not denote the guaranteed performance.

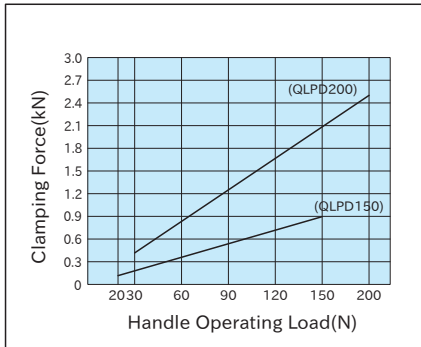

QLTL ADJUSTABLE-TORQUE HANDLES

Use a force gauge when measuring handle-operating loads.

 The performance curves shown below do not denote the guaranteed performance.

