

QCWES

HEAVY DUTY KNOB-LOCKING PINS



QCWES1225-16S

(ON position)

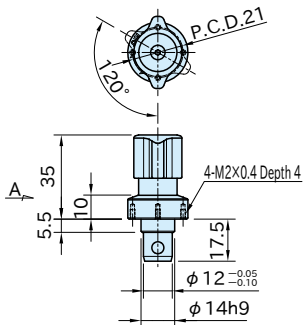

(OFF position)

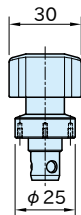

View A

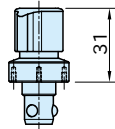

(ON position)

QCWES1225-16S



QCWES1634-20S

(OFF position)

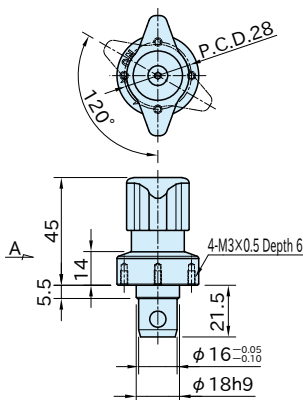

(OFF position)

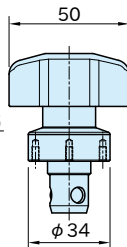

View A

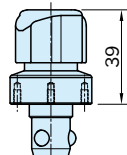

(ON position)

QCWES1634-20S

★Key Point

Strong clamping with 1000N / 2000N

Body	Wedge	Knob	Ball	Spring A	Spring B
SCM440 steel Electroless nickel plated	SCM435 steel Electroless nickel plated Quenched and tempered	SCS13 stainless steel (Equivalent to SUS304)	SUS440C stainless steel Quenched and tempered	Equivalent to SWOSC-V steel	SUS304WPB stainless steel

Part Number	Proper Plate Thickness	Clamping Force (N)	Holding Force (N) **)	Weight (g)	Proper Locking Receptacles
QCWES1225-16S	6~16 *)	1000	2500	150	QCWES1225-B
QCWES1634-20S	6~20 *)	2000	5000	290	QCWES1634-B

*) The tolerance should be within ± 0.05 for 6mm-thick plates.

**) The holding force limits the gap between plates within 0.1mm.

Supplied With

- **QCWES1225-16S**:
4 of socket-head cap screws(stainless steel), M2×0.4-5L
- **QCWES1634-20S**:
4 of socket-head cap screws(stainless steel), M3×0.5-6L

QCWES-B

LOCKING RECEPTACLES



Feature

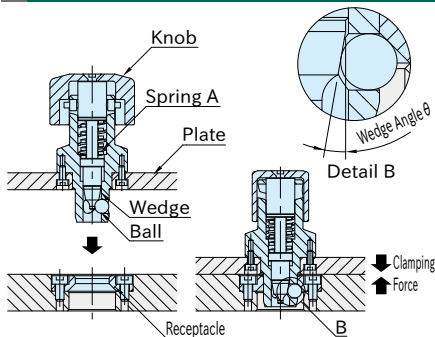

The wedge of the locking pin pushes out the balls against the tapered surface of the receptacle to clamp the two plates.

How To Use

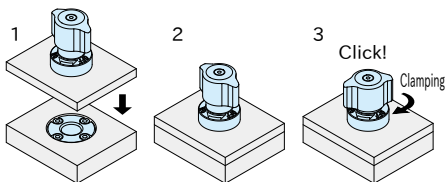

1. Ensure that the knob is positioned at the "OFF" mark.
2. Insert the Knob-Locking Pin
3. Turn the knob to the "ON" mark for clamping. The knob clicks when it is clamped. For unclamping, follow back these steps. The knob turns back to the "OFF" mark by spring force.

Technical Information

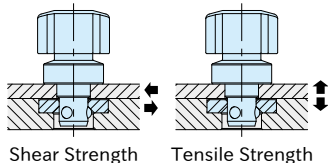

Part Number	Heat-resistant Temperature (°C)	Shear Strength (N)	Tensile Strength (N)
QCWES1225-16S	180	10000	4000
QCWES1634-20S		15000	8000

Shear and tensile strength is allowable load and the fastener could break when it receives bigger load.

Application Example

Changes of machining fixture

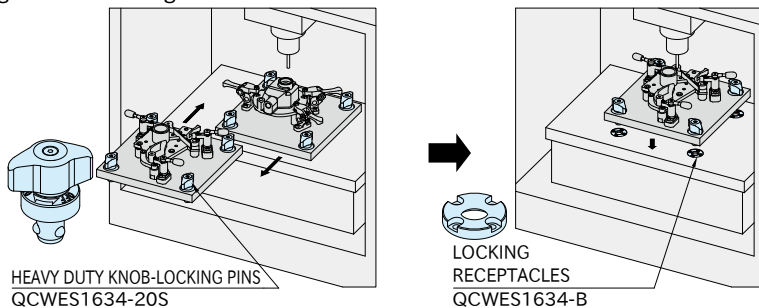

Changes of welding fixture

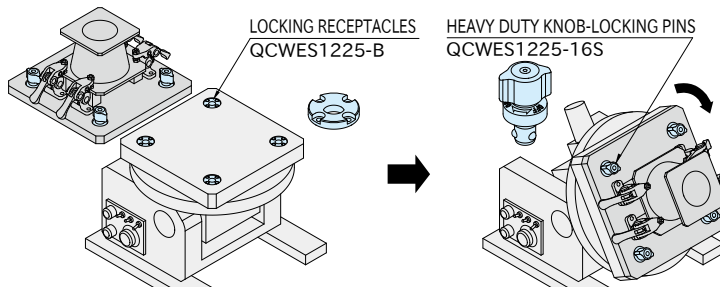

Continuing on Next Page

How To Install

QCWES1225-16S

For 6mm plate

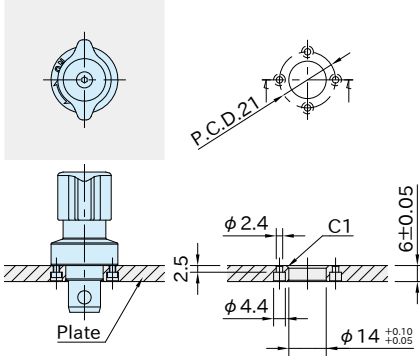

For over 6mm to 16mm plate

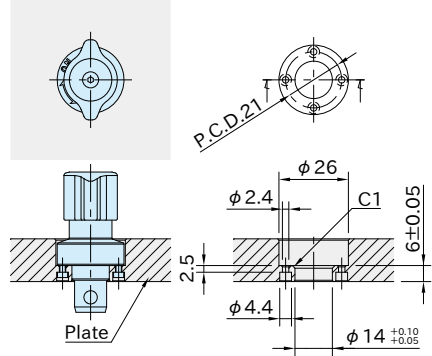

QCWES1634-20S

For 6mm plate

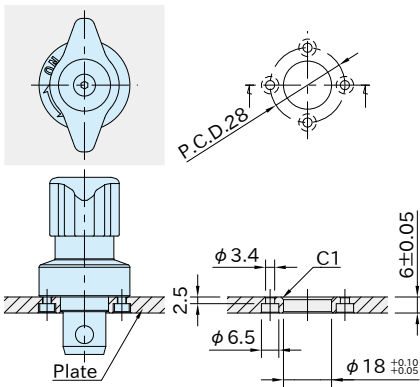

For over 6mm to 20mm plate

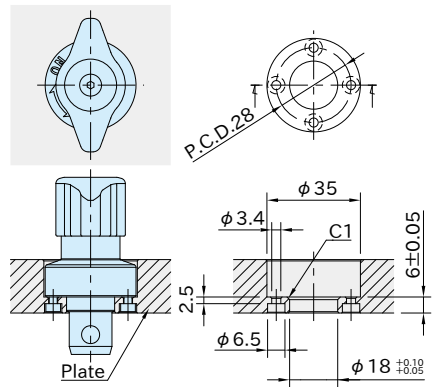

Accuracy

■ Machining Accuracy

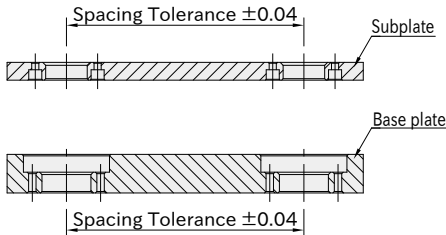

Spacing tolerance on both the subplate and the base plate should be ± 0.04 .

■ Repeatability

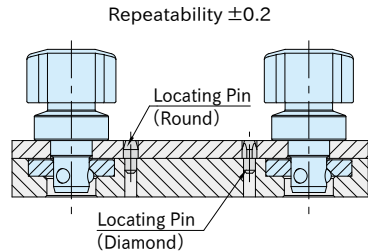

For higher accurate locating, use locating pins.

Performance Curve

Actual Mounting Distance vs. Clamping Force and Operating Torque

QCWES1225-16S

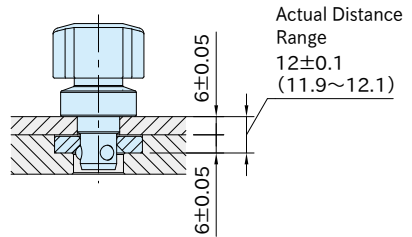
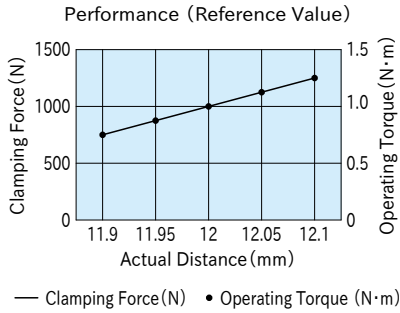

QCWES1634-20S

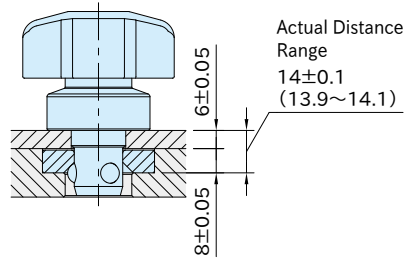
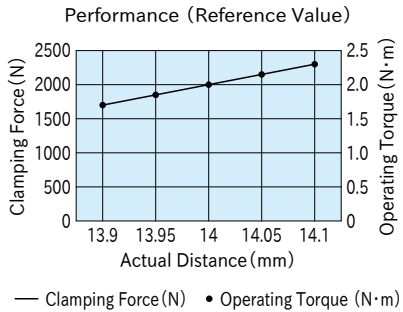

Reference

"How To Install" of [\[QCWES-B\]](#) Locking Receptacles