

MBVRG

ROUND GRIPPERS

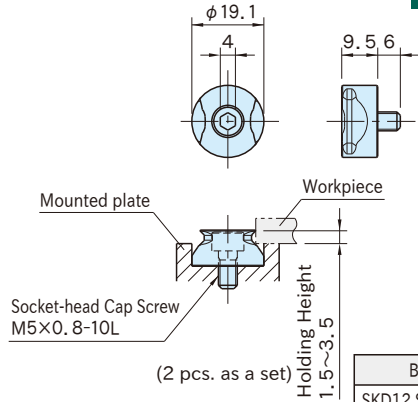

Body
SKD12 Steel
Quenched & tempered
Black oxide finished
HRC52~54

Part Number	Minimum Holding Dia.	Weight (g)
MBVRG19	38	36

Features:

- The sharp edge of the gripper bites into workpieces and holds powerfully.
- Suitable for use as a gripper for vise jaws and a stop of special fixtures.
- The Round Gripper can hold not only circular workpieces but also straight workpieces.
- Grippers allows you to perform aggressive machining operations while holding on as little as 1.5mm.

Notes:

- Use as locating stops for workpieces with hardness less than HRC38.
- The amount of bite of the gripper varies depending on the material and heat treatment etc. of workpieces. Ensure that the gripper edge is biting into the workpieces before machining.

How To Use

Mounting-Hole Dimensions

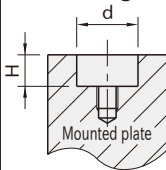

Part Number	d	H
MBVRG19	19.1 ±0.025	6.0~8.0

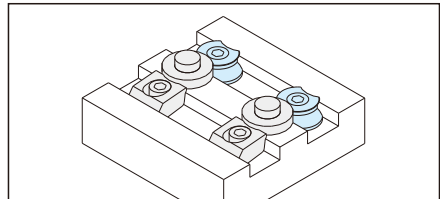

For circular workpieces



For odd shaped workpieces



For large workpieces