

MBSC, MBSSC LOW-PROFILE CLAMPS

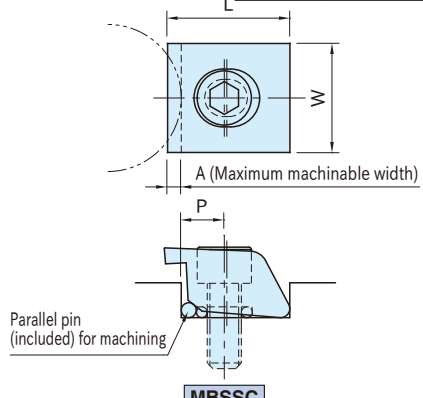

MBSC -A (Knife edge) **MBSC -B** (Blunt edge; Steel) **MBSC -C** (Blunt edge; Brass) **MBSSC** (Machinable edge)

Type	Body
MBSC -A	SKD12 Steel Quenched & tempered Black oxide finished HRC45~48
MBSC -B	SKD12 Steel Quenched & tempered HRC45~48
MBSC -C	Brass
MBSSC	SKD12 Steel HRC43

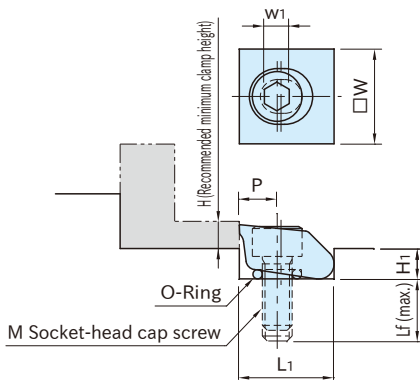

MBSC -A (Knife edge)

MBSC

(Machinable edge)

Part Number	W	H	Clamping Stroke	H ₁	L ₁	P	L _f	M	w ₁	Clamping Force (N)	Allowable Screw Torque (N·m)	Weight (g)
MBSC025A	9.5	1.9	0.19	3.6	9.5	3.8	7	M 2.5×0.45- 8L	2	2,800	1.8	3
MBSC04A	12.7	2.5	0.4	4.8	12.7	5.1	10	M 4 ×0.7 -12L	3	6,600	5.6	7
MBSC06A	19.1	3.8	0.6	7.1	19.1	7.6	13	M 6 ×1 -16L	5	16,000	22.5	21
MBSC10A	25.4	6.4	1.2	11.4	25.4	10.2	20	M10 ×1.5 -25L	8	17,000	40.6	65
MBSC12A	38.1	9.5	1.9	16.3	38.1	15.2		M12 ×1.75-30L	10	50,000	145	200

MBSC -B (Blunt edge; Steel)

Part Number	W	H	Clamping Stroke	H ₁	L ₁	P	L _f	M	w ₁	Clamping Force (N)	Allowable Screw Torque (N·m)	Weight (g)
MBSC025B	9.5	1.9	0.19	3.6	9.5	3.8	7	M 2.5×0.45- 8L	2	2,800	1.8	3
MBSC04B	12.7	2.5	0.4	4.8	12.7	5.1	10	M 4 ×0.7 -12L	3	6,600	5.6	7
MBSC06B	19.1	3.8	0.6	7.1	19.1	7.6	13	M 6 ×1 -16L	5	16,000	22.5	21
MBSC10B	25.4	6.4	1.2	11.4	25.4	10.2	20	M10 ×1.5 -25L	8	17,000	40.6	65
MBSC12B	38.1	9.5	1.9	16.3	38.1	15.2		M12 ×1.75-30L	10	50,000	145	200

MBSC -C (Blunt edge; Brass)

Part Number	W	H	Clamping Stroke	H ₁	L ₁	P	L _f	M	w ₁	Clamping Force (N)	Allowable Screw Torque (N·m)	Weight (g)
MBSC025C	9.5	1.9	0.19	3.6	9.5	3.8	5	M2.5×0.45- 8L	1.5	800	0.6	3
MBSC04C	12.7	2.5	0.4	4.8	12.7	5.1	10	M4 ×0.7 -12L	2.5	1,700	2.8	7
MBSC06C	19.1	3.8	0.6	7.1	19.1	7.6	11	M6 ×1 -16L	4	4,200	5.6	23

MBSSC (Machinable type)

Part Number	W	H	A	Clamping Stroke	L	H ₁	L ₁	P	Lf	M	w ₁	Clamping Force(N)	Allowable Screw Torque(N·m)	Weight (g)
MBSSC10	25.4	6.4	1.5	1.2	27.2	11.4	25.4	10.2	20	M10×1.5 -25L	8	17,000	40.5	68
MBSSC12	38.3	9.5	4.5	1.9	43	16.3	38.1	15.2		M12×1.75-30L	10	50,000	145	213

Features:

- Simple and compact design is perfect for clamping thin workpieces.
- The knife edge of **MBSC-A** allows firm clamping.
- **MBSC-B** and **MBSC-C** are perfect for clamping the workpiece on its finished surface.
- When the clamp is unclamped, the clamping edge is lifted by the O-ring.

Application Examples

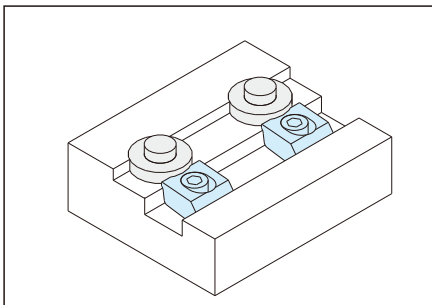
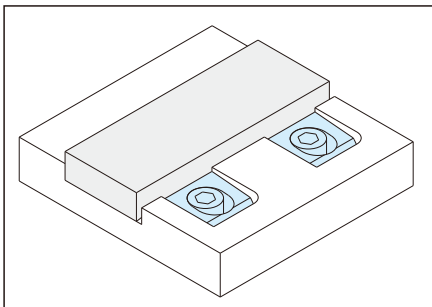
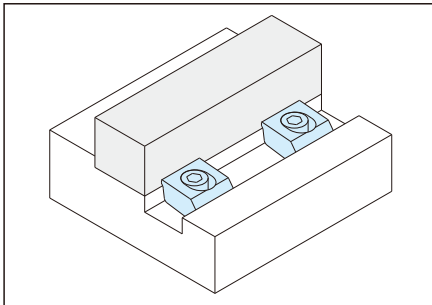

Furnished Parts (Only for Machinable edge type)

Parallel pin 1 of $\phi 6.35 \times 31.75$ for **MBSSC10**
 1 of $\phi 3.175 \times 19.05$ for **MBSSC12**

Notes:

- Use parallel pin for proper location for machining clamp.
- Only for **MBSC-C**, a hex socket button head screw is included.



<Installation Instructions>

1. Machine a slot for the clamp.
2. Drill and tap a hole for the cap screw.
3. Assemble the clamp and loosely screw to fixture.
At this step, there is a clearance created by the O-ring for installation/removal of workpieces.
4. Insert workpiece and tighten cap screw.