

KPHS25105

KPHS25115

Body	Mounting Screw
Spring Steel	SNM625

Part Number	H ₁	H	Weight (g)
KPHS25105	2.5	6.5	20
KPHS25115	7.5	10	22

Feature:

- Simple and compact body is perfect for clamping a thin workpiece.
- Two clamping heights are available.
- The tip of the clamp is composed of three clamping fingers; one rigid finger and two flexible fingers. The two flexible fingers push a workpiece down and the one rigid finger stops a workpiece.

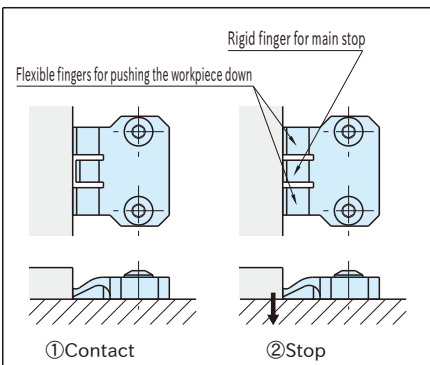

How To Use

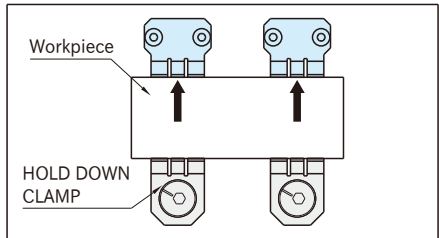
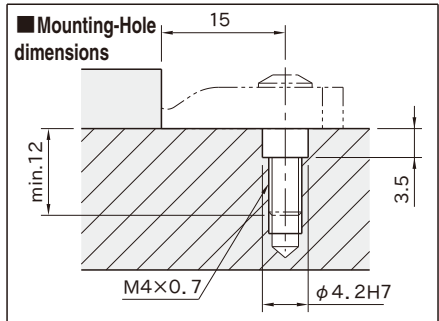

Use Hold Down Stops (Single Stop) for clamping of multiple workpieces.