

# CP127

## JAWS FOR INTERNAL FORM HOLDING

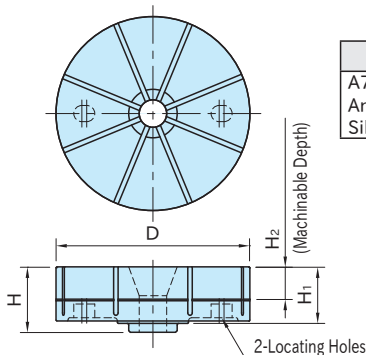
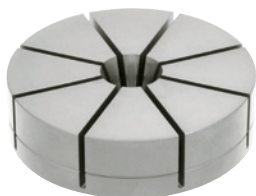

Jaw
A7075 aluminum
Anodized
Silver

Part Number	D	H <sub>1</sub>	H <sub>2</sub>	H	Weight (kg)	Proper	Proper
						CP125 Clamps	CP127-B Screws
CP127-06501	65	25	10	28.5	0.2	CP125-06501	CP127-06501B
CP127-09001	90	30	15	34.5	0.4	CP125-09001	CP127-09001B
CP127-12001	120	35	20	40.5	0.9	CP125-12001	CP127-12001B
CP127-16001	160	40	25	46.5	1.9	CP125-16001	CP127-16001B

**Supplied With**  
1 pc. of O-ring

# CP127-B

## TAPERED SCREWS FOR INTERNAL FORM HOLDING

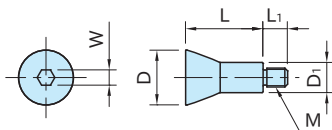

Body
SCM435 steel
Quenched and tempered
Electroless nickel plated

Part Number	D	L	M	L <sub>1</sub>	D <sub>1</sub>	W	Weight (g)	Proper CP127 Jaws
CP127-06501B	22.5	29	M 8×1.25	10	13.2	6	50	CP127-06501
CP127-09001B	27	35	M10×1.5	11	16	8	80	CP127-09001
CP127-12001B	29	41		13			100	CP127-12001
CP127-16001B	33	47	M12×1.75	14	18	10	150	CP127-16001

### Feature

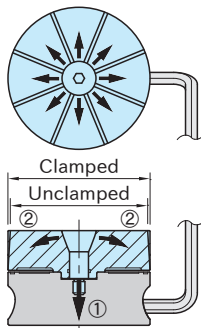

- The tapered screw expands the jaws towards eight directions to hold different irregularly-shaped workpieces securely.
- 0.15mm clamping stroke of each jaw section is perfect for clamping of lost-wax parts, die-cast parts, extruded parts, solid-drawn parts, prefinished parts, etc.

- ① When the cam cylinder is tightened, the tapered screw is pulled down.
- ② At the same time the 8 jaw sections expand to clamp the internal form of workpiece.

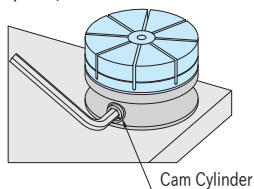

## How To Use

### 1. Jaw Mounting

- Insert an O-ring to the groove on top surface of the Form Holding Clamp.
- Set a Jaw putting its locating holes onto the round locating pins and fix it with a tapered screw.

Note: At jaw installation, ensure the cam cylinder is fully loosened by turning counterclockwise until it stops.

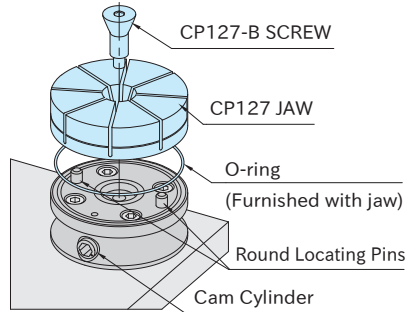

### 2. Jaw Machining

- 2-1. Loosen the cam cylinder fully and measure the dimension of the jaw for machining. Then tighten the cam cylinder until each jaw section expands 0.15mm.

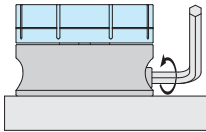

- 2-2. Machine the jaw to the contours of workpiece. (Do not machine the jaws beyond the machinable depth.)

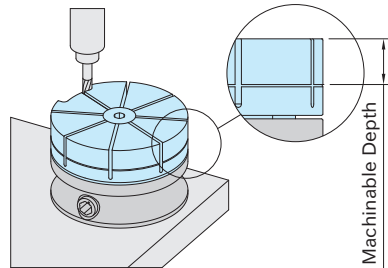

### 3. Workpiece Loading

After machining loosen the cam cylinder to set workpiece and tighten the cam cylinder again for clamping.

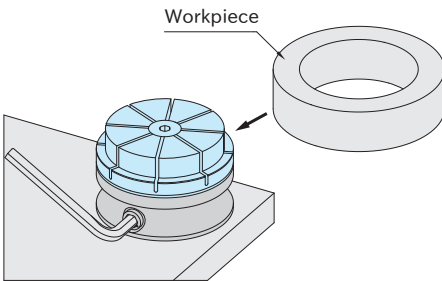

## Performance Curve

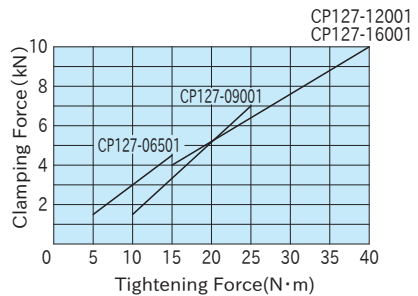

### Note

Do not tighten the cam cylinder without the workpiece set to prevent damage and deformation. Tightening with the torque beyond the allowable screw torque will lower the durability of the jaw.