

# CLT94CB

# CAM BLOCK

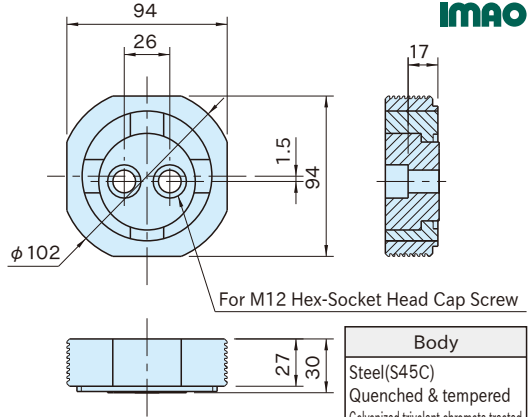

Part Number	Weight (kg)
<b>CLT94CB</b>	1.5

### Features:

- The eccentric cam provides fast clamping with a key.
- The eccentric and propeller principle provides strong clamping by double locking of axial and radial.

### Technical Information:

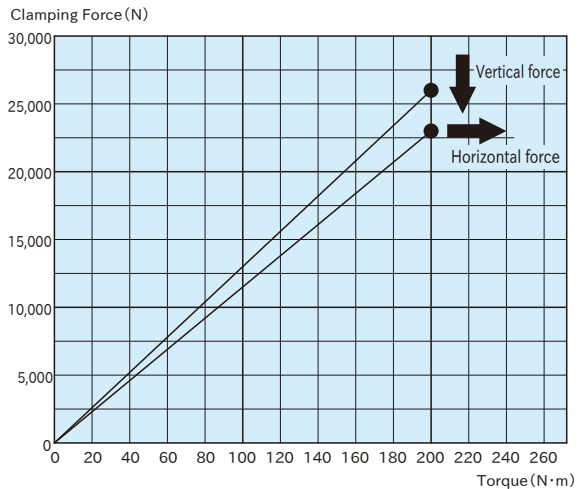

### Application Example

- Available with either serrated or smooth faces to hold different figure workpieces.
- **CLT-L** Cam Block Key for tightening are available separately.
- **CLT-T** T-Nuts to set in the T-slots are available separately.

