

CLS58CB

CAM BLOCK

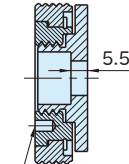
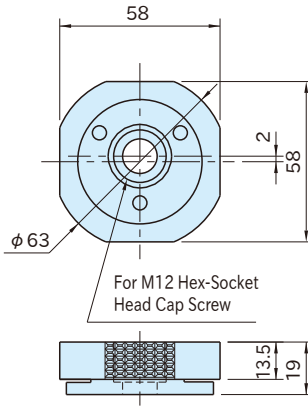

*) For loading workpieces, tighten the cam fully and then loosen it one turn.

Part Number	Weight (kg)
CLS58CB	0.5

Body
Steel(S45C)
Quenched & tempered
Galvanized trivalent chromate treated

Features:

- The eccentric cam provides fast clamping with a handle.
- The eccentric and propeller principle provides strong clamping by double locking of axial and radial.

Technical Information:

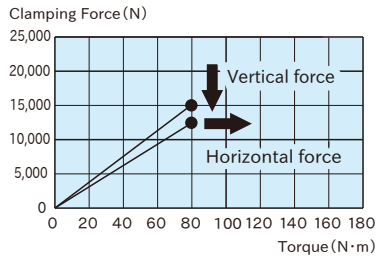

Application Example

- Available with either serrated or smooth faces to hold different figure workpieces.
- **CLS-L** Cam Block Key for tightening are available separately.
- **CLS-T** T-Nuts to set in the T-slots are available separately.

