

BJ112

SCREW CLAMPS

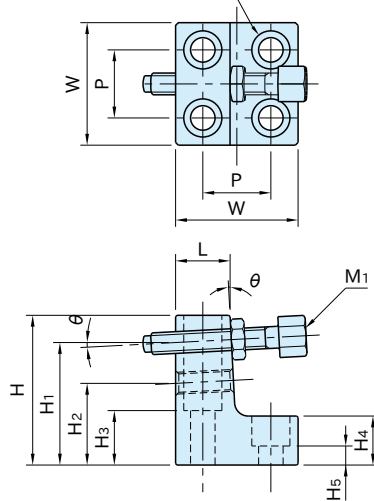

For M-Socket-Head Cap Screws



Body	Screw
S45C steel Black oxide	SCM435 steel Quenched and tempered Black oxide

Part Number	M ₁	H ₁	H ₂	W	H	L	θ	M	P	H ₃
BJ112-08025	M 8×1.25-50L	45	30	45	55	20	3°	M 8	25	20
BJ112-16050	M16×2 -80L	75	50	85	90	33	5°	M16	50	33

Part Number	H ₄	H ₅	Clamping Force (kN)	Allowable Screw Torque (N·m)	Weight (kg)
BJ112-08025	18	7	15.6	25	0.45
BJ112-16050	27	10	62.3	200	2.3

How To Use

