

ALV

ALUMINUM ANGLED-SPOKE HANDWHEELS



ALV-N

(Without Handle-Mounting Tapped Hole)



ALV

(With Handle-Mounting Tapped Hole)

Note: Handle must be ordered separately.

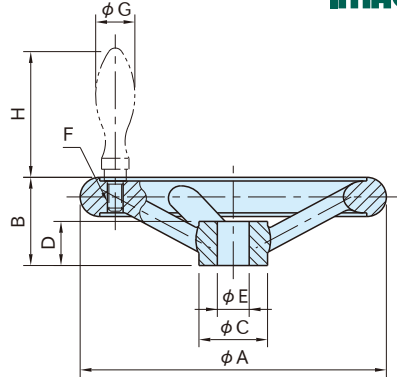

Handwheel
Aluminum alloy (AC4B)
Buffed finish

Without Handle-Mounting Tapped Hole	With Handle-Mounting Tapped Hole		No. of Spokes	A	B	C	D	E (H8)	Weight (g)	
Part Number	Part Number	F								
ALV 80N	ALV 80	M 6x1	3	80	29	24	16	10	125	
ALV100N	ALV100			100	33	26	17		220	
ALV125N	ALV125	M 8x1.25		125	36	32	18	12	305	
ALV140N	ALV140			140	39		19	14	400	
ALV160N	ALV160	M10x1.5		160	40	35	20		16	530
ALV180N	ALV180			180	43		22	675		
ALV200N	ALV200	M12x1.75		5	200	45	42	24	18	900
ALV225N	ALV225				225	48	26	20	1,240	
ALV250N	ALV250		250		50	48	28	22	1,570	
ALV280N	ALV280		280		53	50	30	24	2,220	
ALV315N	ALV315		315		56	53	33	26	2,490	

With Handle-Mounting Tapped Hole Part Number	Recommended Aluminum Fixed Handles			Recommended Aluminum Revolving Handles		
	Part Number	G	H	Part Number	G	H
ALV 80	ALG16	16	50	ALG16R	16	54.5
ALV100						
ALV125	ALG20	20	64	ALG20R	20	67
ALV140						
ALV160	ALG25	25	80	ALG25R	25	83
ALV180						
ALV200						
ALV225	ALG32	32	100	ALG32R	32	105.5
ALV250						
ALV280						
ALV315						

Notes

Slight dimensional variations can be caused due to buffed finish.