

# KCLF, KCLFS

# 凸轮手柄

RHS SUS



★ One Point  
外螺纹固定型

类型	手柄	垫圈、外螺纹	圆形螺母	推力垫圈
<b>KCLF</b>	铝压铸 黑色粉末烤漆	SUM22L 锌三价铬酸盐	SUS303	聚酰胺 (玻璃纤维强化)
<b>KCLFS</b>		SUS303		

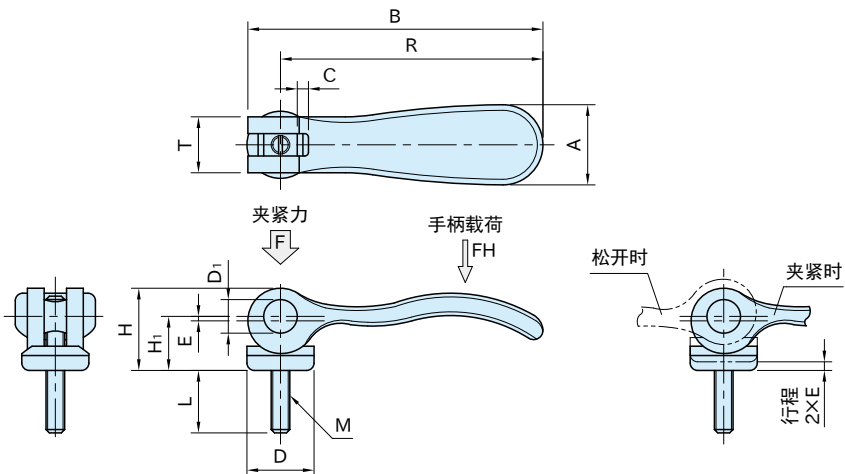

规格		E	H <sub>1</sub>	R	A	D	M	B	T	H	D <sub>1</sub>	C	夹紧力 F(kN)	手柄载荷 FH(N)
<b>KCLF</b> <b>KCLFS</b>	<b>03</b>	1	9	36.2	14.4	12	M 3×0.5	41.7	11.5	13	6	0.5	1.5	90
	<b>04A</b>						M 4×0.7							
	<b>04</b>	1	11.2	52.3	18	15.4	M 4×0.7	59.1	13	17	8	2	2.5	100
	<b>05A</b>						M 5×0.8							
	<b>05</b>	1.2	14.5	70.4	21.5	18.1	M 5×0.8	79.2	15	22	9	3	4	120
	<b>06</b>						M 6×1							
	<b>08</b>	1.5	18	96	33.3	27.1	M 8×1.25	108	24	28.5	11	5	8	350
	<b>10</b>						M10×1.5							

KCLF		KCLFS		L
型 号	质量 (g)	型 号	质量 (g)	
KCLF03 × 10	9	KCLFS03 × 10	11	10
KCLF03 × 15		KCLFS03 × 15	12	15
KCLF03 × 30	12	KCLFS03 × 30		30
KCLF04A × 10	9	KCLFS04A × 10		10
KCLF04A × 15	10	KCLFS04A × 15		15
KCLF04A × 30		KCLFS04A × 30	13	30
KCLF04 × 15	19	KCLFS04 × 15	20	15
KCLF04 × 20		KCLFS04 × 20	21	20
KCLF04 × 30	20	KCLFS04 × 30		21
KCLF05A × 20	22	KCLFS05A × 20	22	20
KCLF05A × 30	21	KCLFS05A × 30	24	30
KCLF05A × 40		KCLFS05A × 40		40
KCLF05A × 50	26	KCLFS05A × 50	26	50
KCLF05 × 20	37	KCLFS05 × 20	38	20
KCLF05 × 30	40	KCLFS05 × 30	39	30
KCLF05 × 40		KCLFS05 × 40	40	40
KCLF05 × 50	41	KCLFS05 × 50	42	50
KCLF06 × 20		KCLFS06 × 20	40	20
KCLF06 × 30	42	KCLFS06 × 30	42	30
KCLF06 × 40		KCLFS06 × 40	44	40
KCLF06 × 50		KCLFS06 × 50	46	50
KCLF08 × 25	115	KCLFS08 × 25	113	25
KCLF08 × 30	114	KCLFS08 × 30	116	30
KCLF08 × 40	118	KCLFS08 × 40	119	40
KCLF08 × 50	121	KCLFS08 × 50	114	50
KCLF10 × 25	119	KCLFS10 × 25	121	25
KCLF10 × 30	128	KCLFS10 × 30	122	30
KCLF10 × 40	130	KCLFS10 × 40	128	40
KCLF10 × 50	133	KCLFS10 × 50	132	50

### 特 点

- 如果拧入合适的量，仅操作手柄使之压下、抬起，就可夹紧、松开。
- 因为螺丝部是和手柄固定的，所以手柄的方向不可调节。